

FIRE DOOR 3

LVN25 NON-VISION AIR TRANSFER GRILLE INTO TIMBER FIRE DOOR

DESCRIPTION

- 1 FD30: Minimum 50mm thick timber fire door
FD60: 54mm thick timber fire door
- 2 Aluminium mounting flange
- 3 Intumescent air transfer grille to door fasteners - 25mm wood screws
- 4 LVN25 intumescent air transfer grille

In order to comply with CF564, the upper edge of the grille shall be no higher than 800mm from floor level. Consult door manufacturers before cutting out in relation to permissible aperture sizes and locations

If the door leaf core does not comprise a solid timber lamel core (i.e. a core of chipboard, flaxboard etc.), the aperture provided in the leaf should be lined to full width using hardwood, with a minimum density of 650kg/m³ and a thickness of at least 6mm. This hardwood liner may be omitted should the leaf have been tested.

CONTENTS

- LVN25 air transfer grille
- Aluminium mounting flange (optional)

TOOLS REQUIRED

- Power drill
- Screw driver
- 25mm wood screws
- Lorient intumescent sealant

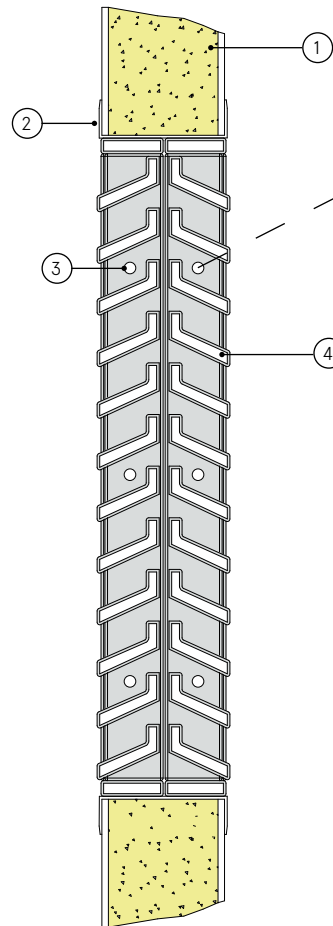

Note: Screw holes based on 450mm square grille. Location and number may vary depending on the size of the grille. Max centres 200mm.

LVN25 into a timber fire door

FD30/FD60

Fire Resistance in accordance with

BS 476-22:1987

Approval Ref

WFRC C122567*
Certifire CF564**

Max single cell size

0.36m²*
0.2025m²**

LVN25 air transfer grilles are supplied 2mm less than the nominal size e.g. a 300mm x 300mm is actually 298mm x 298mm, but the PVC mounting flange needs an extra 4mm overall, giving total dimensions 2mm greater than the nominal size. e.g. 302mm x 302mm.

INSTALLATION INSTRUCTIONS

- ▶ Ensure that cutting an aperture in the door will not detract from the fire integrity of the door. Contact the manufacturer to establish the maximum size and optimum position.
- ▶ Cut the aperture to the required size with a maximum gap all around of 3mm. e.g. Maximum dimensions 306mm x 306mm.
- ▶ The door leaf does not compromise a solid timber lamel core (i.e. a core of chipboard, hardboard etc.), the aperture provided should be lined to the full width using hardwood (minimum density of 650kg/m³ and thickness of 6mm).
- ▶ Apply a bead of Lorient intumescent sealant around the aperture approx. 1cm from both sides of the door surface. This will provide a bed for the LVN25.
- ▶ Pre-drill vertical outer frames of LVN25 to accept fixing screws.
- ▶ Fit a half of the LVN25 into the aperture and ensure that it is positioned with the flange snug to the face.
- ▶ Fit retaining wood screws through pre-drilled holes in LVN25 vertical outer uprights into door.
- ▶ Clean off surplus sealant and ensure periphery of half of the LVN25 is fully sealed.
- ▶ Repeat the process with the remaining half of the LVN25.
- ▶ **Note: Fixings supplied by others.**